

unità di guida

guiding units



TIPO "H" PER CILINDRI ISO 15552

type "H" for cylinders ISO 15552

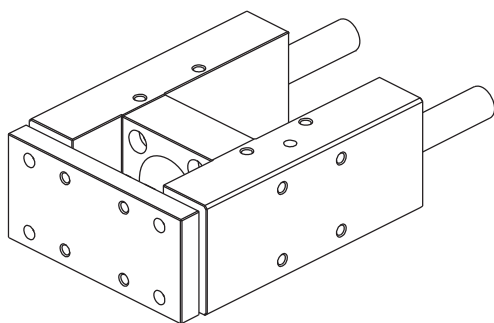
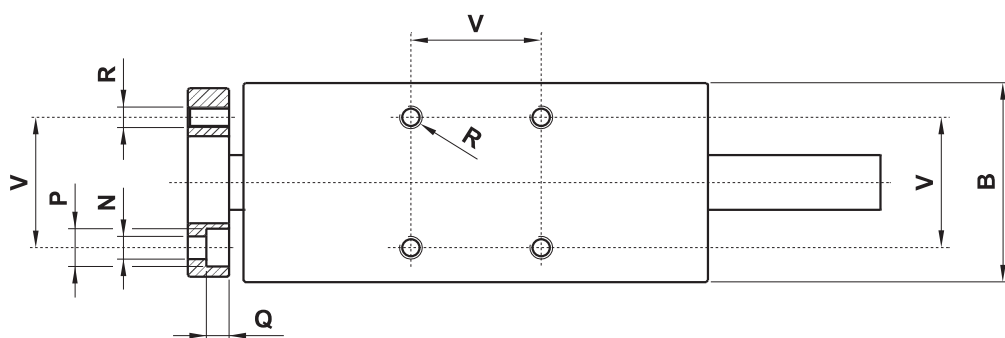
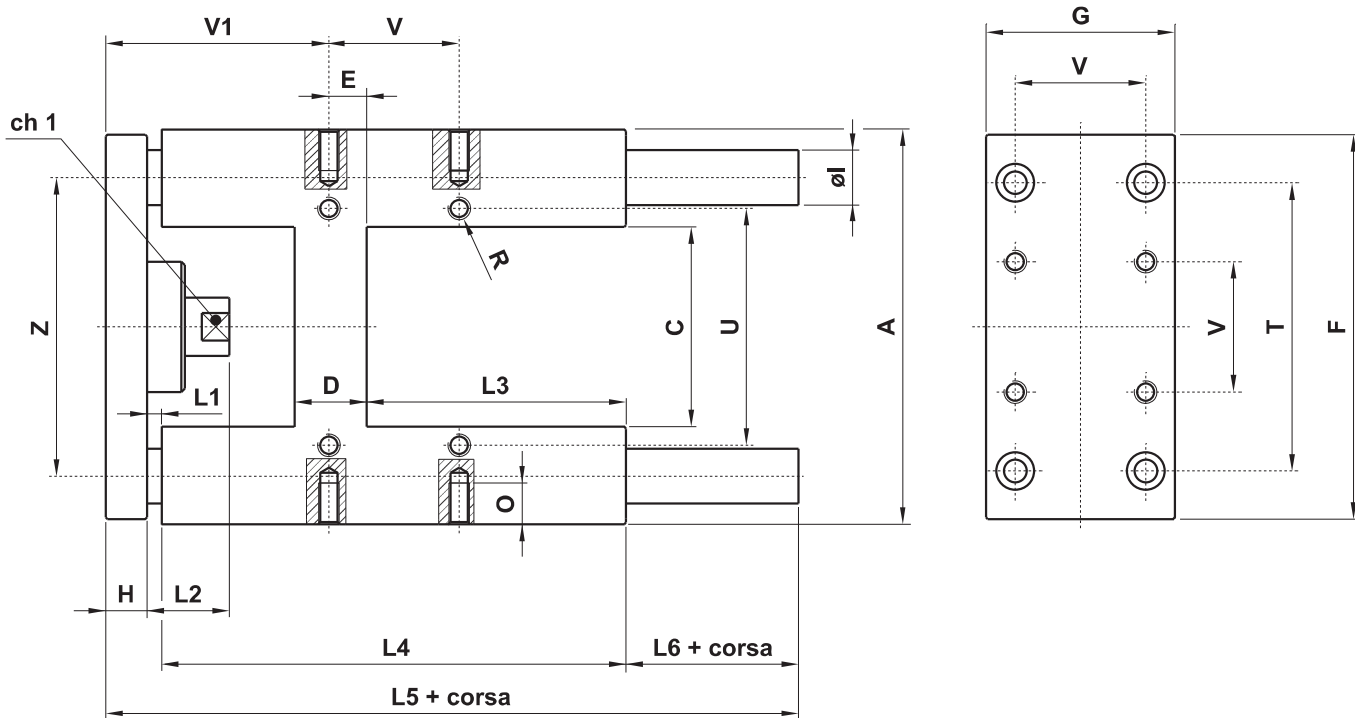

niplo corto
short coupling

peso (g)
weight (g)

ø CIL	cilindro corsa 0 cylinder stroke 0	incremento corsa 100 mm 100 mm stroke increase
32	1300	180
40	2400	320
50	3500	500
63	4600	500
80	8400	770
100	11800	770

niplo lungo
long coupling

ø CIL	L1	L2	L6	V1
32	26	42	24	83.7
40	25	42	30	86
50	25	50	35	91.2
63	25	50	25	96.7
80	25	50	27	104
100	25	50	27	105

ø CIL	A	B	C	ch	D	E	F	G	H	øl	L1	L2	L3	L4	L5	L6	N	O	P	Q	R	T	U	V	V1	Z
32	97	49	51	15	24	4.3	93	45	12	12	3	19	75	125	187	47	6.6	12	11	6.5	M6	78	61	32.5	60.7	74
40	115	58	58.2	15	28	11	112	55	12	16	3	24	80	140	207	52	6.6	12	11	6.5	M6	84	69	38	64	87
50	137	70	70.2	20	34	18.8	134	65	15	20	3	27	78	148	223	57	9	16	15	8.5	M8	100	85	46.5	69.2	104
63	152	85	85.2	20	34	15.3	147	80	15	20	3	27	106	178	243	47	9	16	15	9	M8	105	100	56.5	74.7	119
80	189	105	105.5	26	50	25	180	100	20	25	3	27	111	195	267	49	11	20	18	11	M10	130	130	72	82	148
100	213	130	130.5	26	55	30	206	120	20	25	3	27	128	218	290	49	11	20	18	11	M10	150	150	89	83	173